

NUWEIGH

STAINLESS STEEL SCALE FRAME JAC949/959MK11-SF

FEATURES

- High quality stainless steel structure
- Low maintenance, corrosion resistant scale frame
- Functional design for easy cleaning and protection
- Integrated foot platforms provide strong support
- Adjustable rubber feet
- Ideal solution for commercial establishments, kitchens, food processing plants and abattoirs
- Custom bespoke options and sizes available
- Optional stainless steel roller castors



The perfect accessory for
JAC949/959MK11 scales!

DIMENSIONS

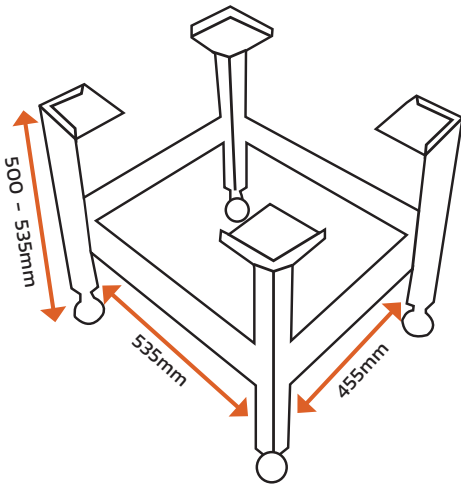

PRODUCT	INV NO.
JAC949/959MK11-SF	#36515

