

NUWEIGH

MILD STEEL WEIGH BEAMS MIL589

The **MIL589 WEIGH BEAMS** can be separated to allow any item to be weighed. Due to their **versatility and portability** they are ideal for weighing materials & products of various sizes and can also be installed in a fixed location.



Includes: **HEAVY DUTY PROTECTIVE CASE**

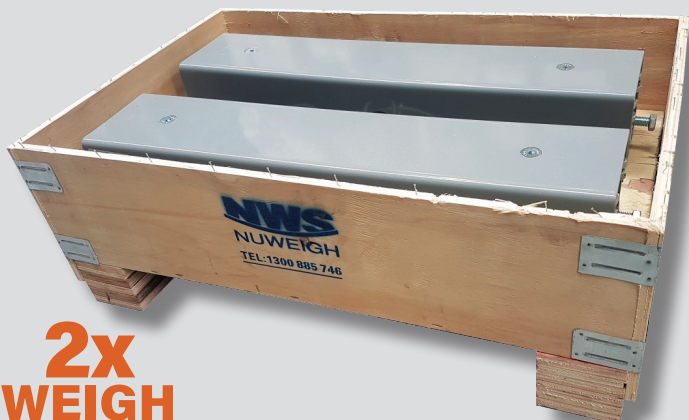

**2x
WEIGH
BEAMS
INCLUDED**

Includes: **NUWEIGH JAC101-D INDICATOR**

- Large 26mm LCD back-lit display
- 240V & rechargeable battery
- Battery operated
- Memory accumulation function
- Counting function
- Protective dust & water resistant cover
- NMI approved*
- Shown above with optional NUWEIGH IH519 Pole Stand

FUNCTIONS

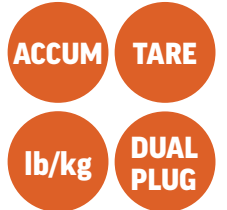

SIZE	CAPACITY	DIVISIONS	PART NO.
600mm	1500/3000kg	0.5/1.0kg	#1715
1000mm	1500/3000kg	0.5/1.0kg	#1714

NWS
NUWEIGH

NUWEIGH AUSTRALIA

NATIONAL SERVICE AND SALES NSW | VIC | ACT | QLD | NT | SA | WA | TAS

1300 885 746 | sales@nuweigh.com.au | www.nuweigh.com.au

Newcastle Weighing Services EST.1976 | ABN 36 001 344 430

NUWEIGH

MIL589 FEATURES

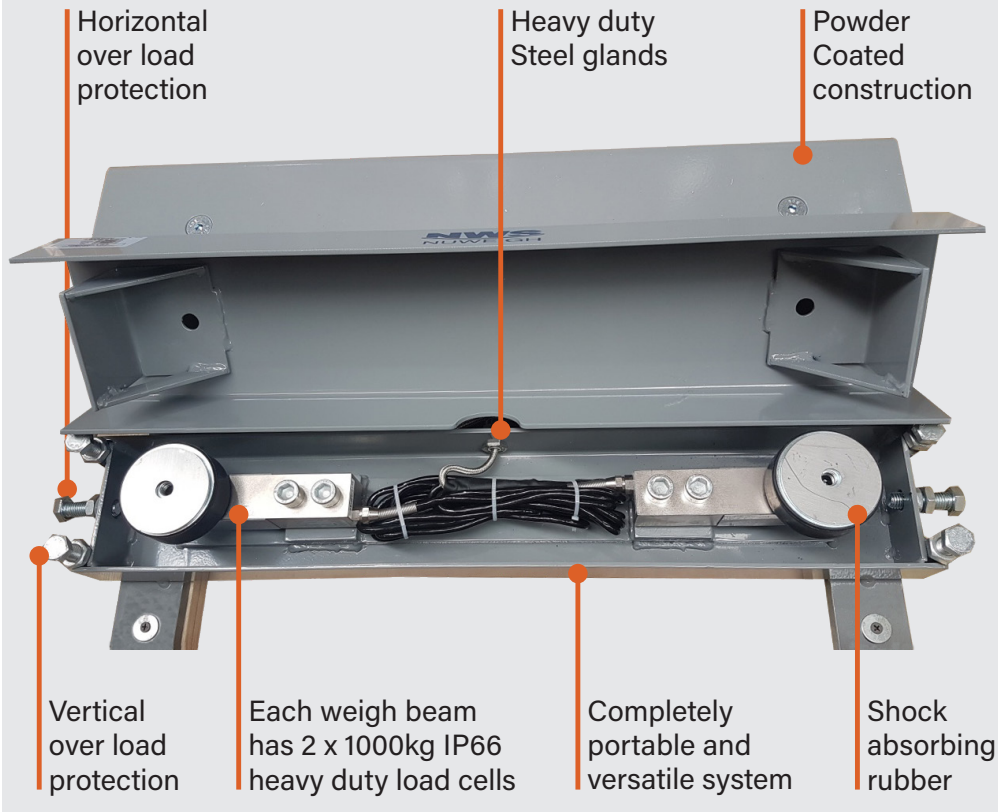

Dual plug indicator



Standard 4 metres of braided cable from each beam to the weighing indicator



Supplied in purpose built, protective wooden crate

*NMI Trade approved only when fitted with a load receptor and in a fixed location. The multi-purpose design suits weighing applications such as warehousing, pallets, cattle and other large animals.

DIMENSIONS

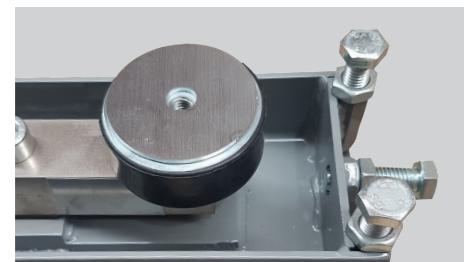
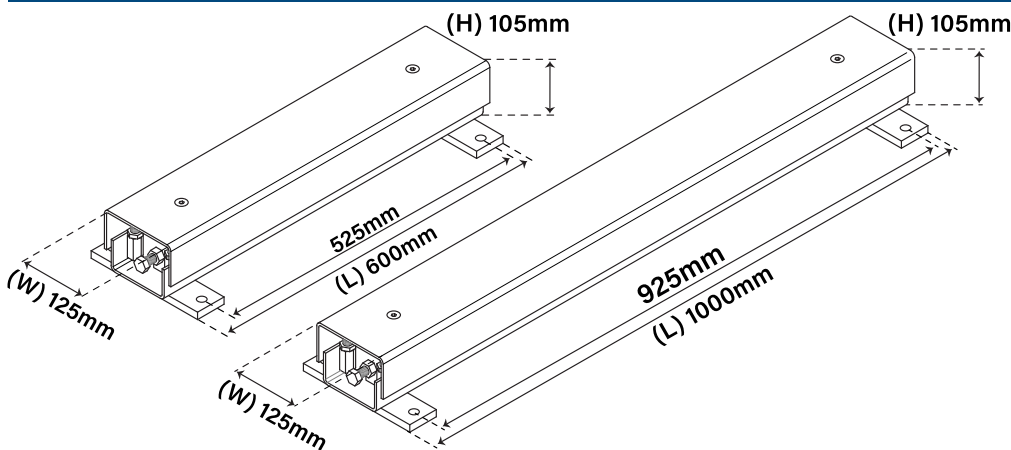

Horizontal & vertical impact protection