

NUWEIGH

SWN-790

DYNAMIC BELT SCALE INTEGRATOR



7 Colour Backlight Display Changes to Red when not active or in error state and Green when in normal operation.

Simple Calibration and programming with the user prompts on the full graphic display.

Configurable Security Password protection.

Shift Totals by hour / day / month.

Rugged Industrial Design.

High Accuracy with 3 point linearity adjustment.

Waterproof Keypad.

Clear Easy to read Graphic Display.

Audit trail counter feature.



PANEL MOUNT



Green display normal operation

CABINET MOUNT



Red display not active or in error

The SWN-790 belt scale integrator has been designed for rugged industrial use to ensure the highest level of accuracy possible when installed on all types of dynamic weighing instruments. NUWEIGH Australia has extensive experience with belt weighing applications. We have invested all of our experience into the design of the SWN-690 Integrator. Offering both Legal for Trade and Non Trade options from an accuracy of 0.25%. Nuweigh Australia can offer you a quality long term solution that will deliver accurate results with high level interfacing to your external equipment.

SWN-790

SWN - 790 SPECIFICATIONS

Display	128 x 64 Graphic LCD Display 7 Colour Backlight
Keypad	6 Key User Friendly Keypad
Power Supply	240 volt 50 Hz 110 volt 50/60 Hz (optional)
Load Cell Input	Power for up to 8 x 350 Ohm Load Cells Input Signal from 0.5mV/V to 3mV/V Excitation Voltage 10VDC 24 Bit A/D Convertor
Speed Input	Frequency Range 0.5~5000Hz Output Power 5~24volts VDC 100mA Max
Digital Inputs	3 Configurable Digital Inputs
Digital Outputs	4 Configurable Digital Outputs
Communications	RS 232 Standard Optional RS 485, RS422, Profibus DP, Ethernet
Environmental	Operating Temp -20°~+70° Panel Mount Version IP54 Cabinet Mount Version IP65
Alarms	Flow Rate, Belt Load, Speed, Calibrating, Error
Calibration	3 Point Linearity Span Direct Calculated Span Adjustment

Optional Stainless Steel Enclosure

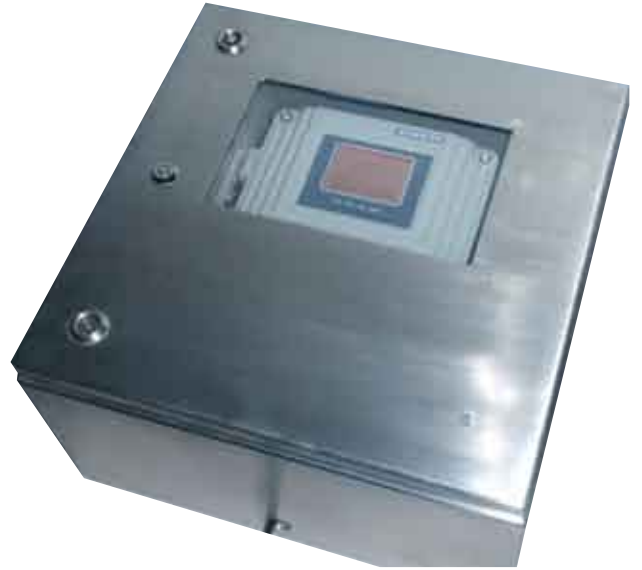

Robust electronics for Industrial Environment

Cast Enclosure

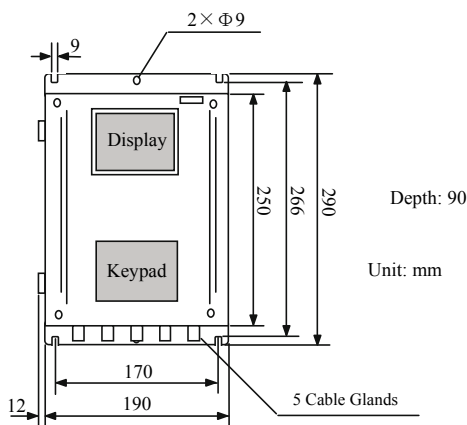

Panel Mount

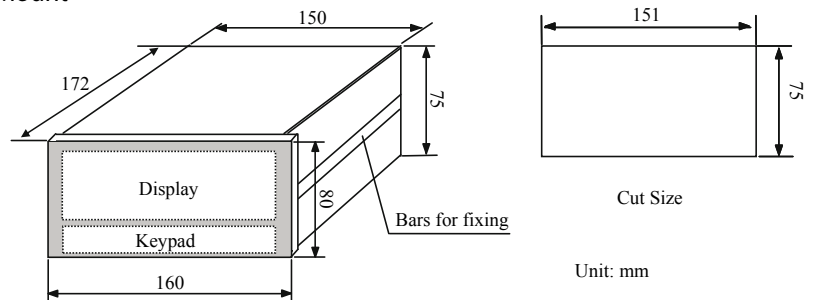

PANEL MOUNT #2664
CABINET MOUNT #35946