

NUWEIGH

NWS
NUWEIGH

JAC 190

#4119

HIGH-TEMPERATURE. HIGH-PRESSURE
WASHDOWN

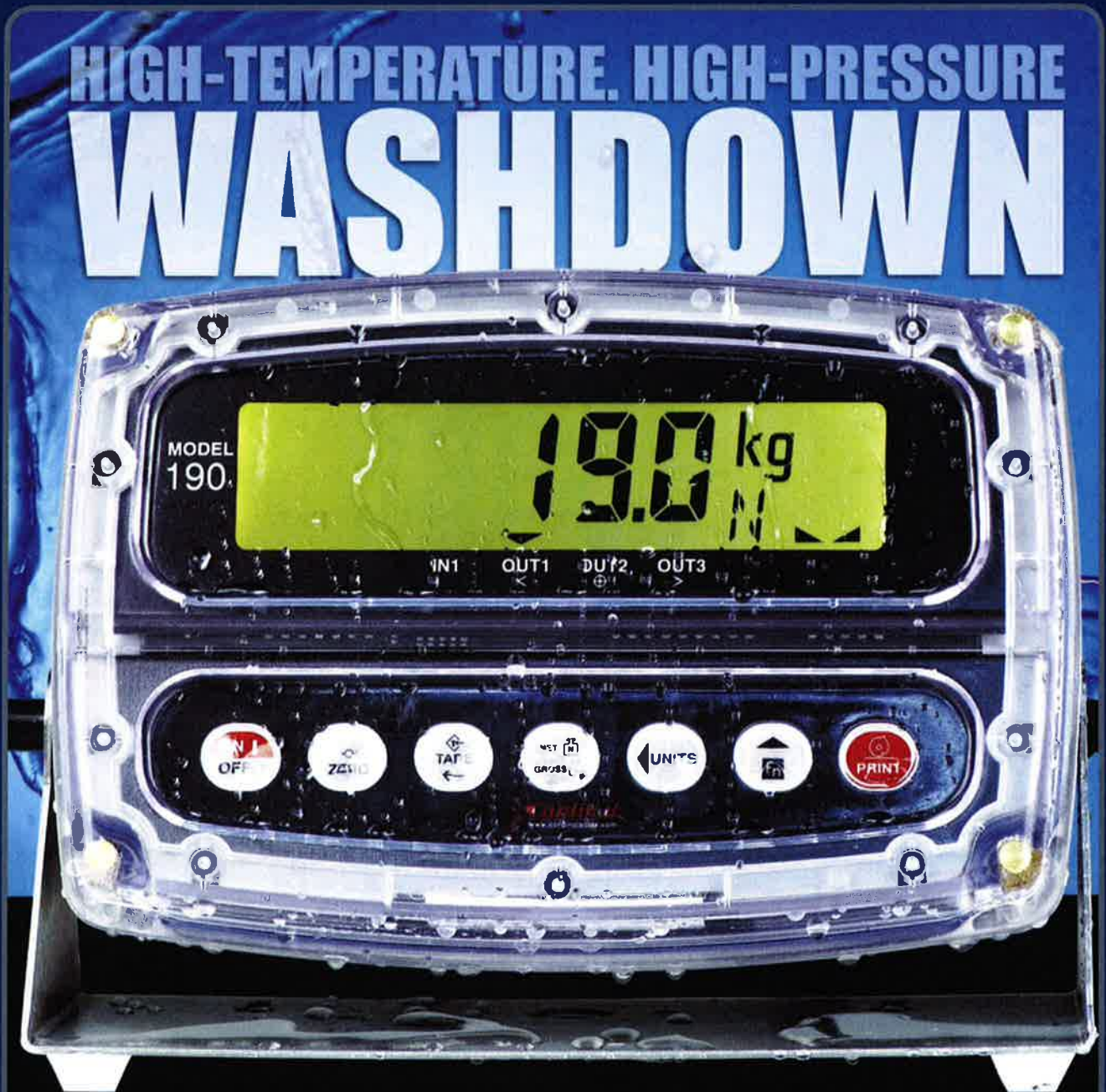

Weight Indicator

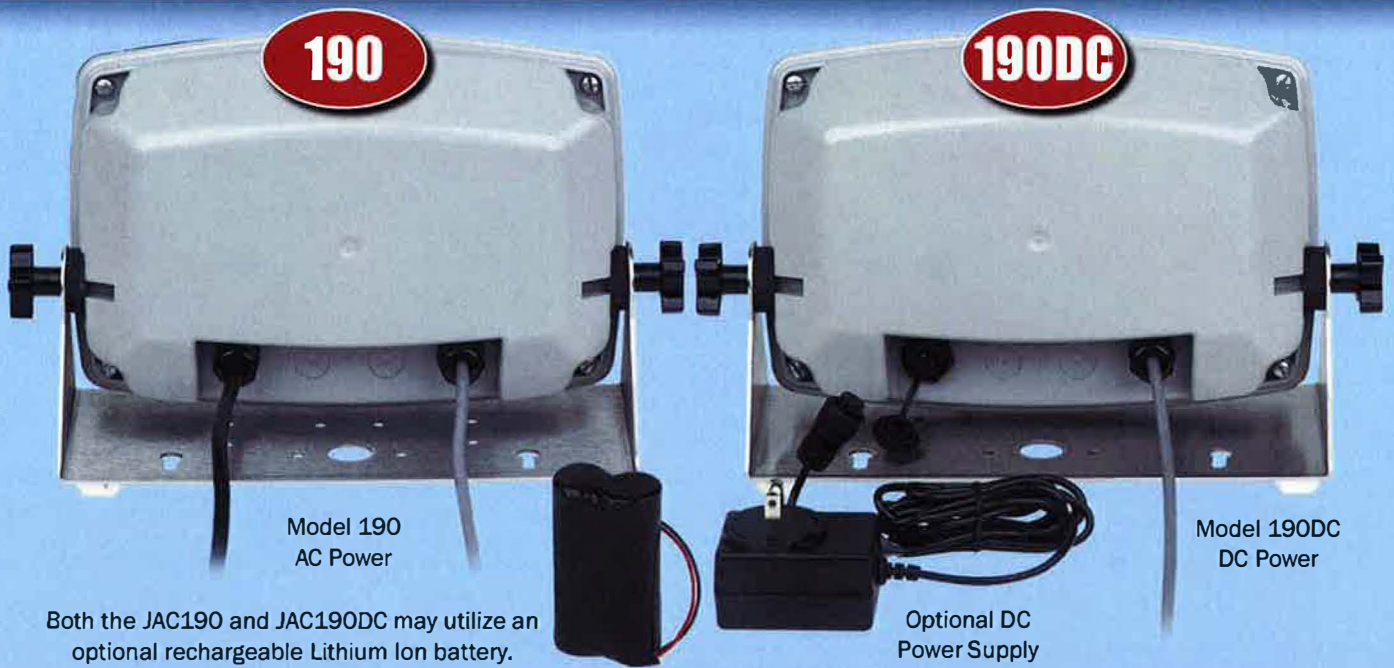

190

190DC

Model 190
AC Power

Model 190DC
DC Power

Both the JAC190 and JAC190DC may utilize an optional rechargeable Lithium Ion battery.

Optional DC
Power Supply



CAPACITIVE TOUCH KEYS

Capacitance is the ability of a person to hold an electrical charge, so Nuweigh's JAC190 unique capacitive touch keys allow the front of the panel to be constructed as a single piece. The keypad senses the operator's finger from the inside of the enclosure. There are no moving parts to wear out or exposed electronics. Red status lamps above each key provide a visual indication of keypresses, as shown here.



ULTRA-TOUGH ENCLOSURE

The combination of the rugged polycarbonate enclosure and capacitive touch keys provide total protection from sharp objects. The JAC190 is impact resistant for ultimate durability in harsh environments. The IP69K watertight, highly-durable enclosure provides you with the assurance of dependability that you require.

COLOURZONE CHECKWEIGHING

ColourZONE is the solution for efficient time management during your checkweighing processes. The bright, vivid display, changes colour automatically as the pre-assigned target weights are reached. You know immediately when you've hit the acceptable weight range. The JAC 190 displays amber for under weight, green for accepted weights, and bright red when weights exceed the upper weight limit. The target weights are easy to assign through the JAC190's capacitive touch keypad and can be changed quickly as different sized products are weighed.

OVER

192 kg

ACCEPT

190 kg

UNDER

188 kg

Nuweigh's JAC 190 high-impact indicator is perfect for:

- Food Processing
- Chemical Industry
- Pharmaceutical
- Almost any harsh application environment

IP69K

With an IP69K rating, the JAC 190's enclosure is designed for high pressure water jet cleaning (1450PSI) at high temperatures of up to 80°C.

WASHDOWN

Model JAC 190 WEIGHT INDICATOR

- **Large 25mm-high clearly-visible LCD**
- **Versatile power options: AC, DC, and rechargeable battery**
- **Built-in RS232 communications port**
- **Highest protection rating possible**

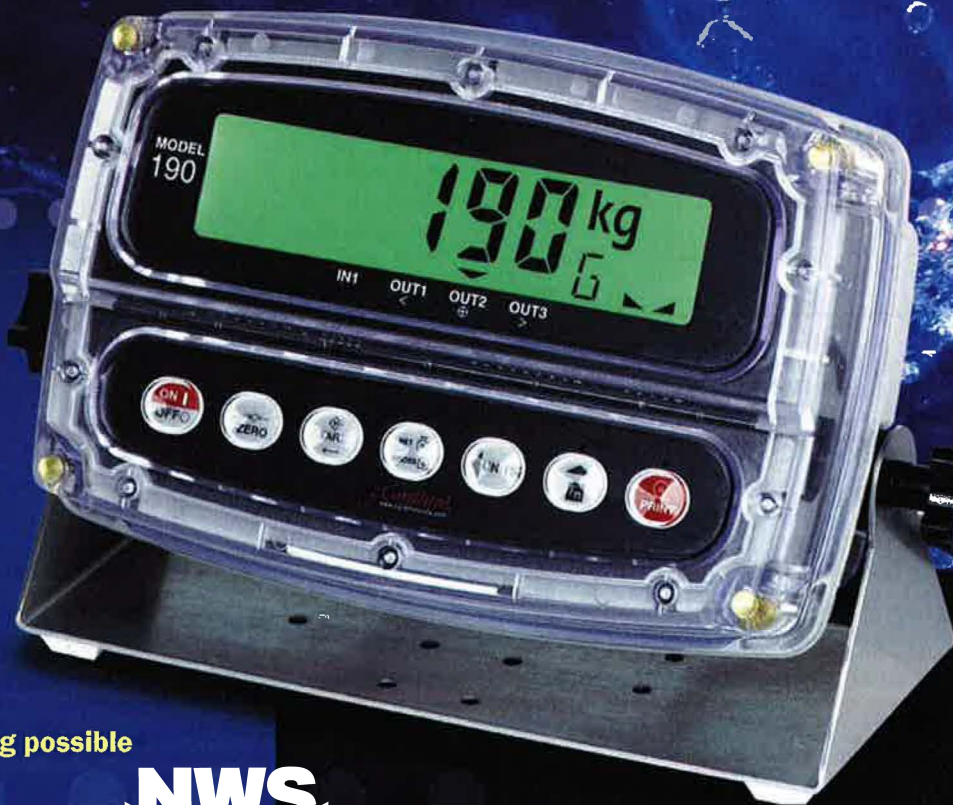

NWS
NUWEIGH

JAC190 SPECIFICATIONS

| | |
|--------------------------------|---|
| Power Requirements: | 100 to 240 VAC (50/60 Hz) at 0.4A Max. / 190DC: 10.5 to 30 VDC 1.0A Max. |
| Enclosure Type: | Thermoplastic IP69K wall or desk-mount |
| Enclosure Size: | 239 mm W x 163 mm H x 93 mm D |
| Operating Environment: | Temperature: -10 to +40 °C Humidity: 90% non-condensing (maximum) |
| Display: | Six digit, seven segment, 25mm high Backlit LCD |
| Transducer Excitation: | 5.18 VDC |
| Signal Input Range: | 0.5 mV min. to 40 mV max. (with dead load boost) |
| Number of Load Cells: | 6 each, 350 OHM minimum resistance |
| Load Cell Cable Length: | 45 metres maximum. 9 metres maximum without sense lines <i>Consult factory for other requirements</i> |
| Internal Resolution: | 1 part in 16,777,216 |
| Tare Capacity: | Scale Capacity |
| Sample Rate: | 1 to 100 samples per second, selectable |
| Auto Zero Range: | 0.5 or 1 through 9 divisions |
| Weighing Units: | Pounds, Ounces, Kilograms, Grams |
| Keypad: | Color Coded Capacitive Touch type, 7 keys |
| Standard I/O: | (1) bi-directional RS232 |

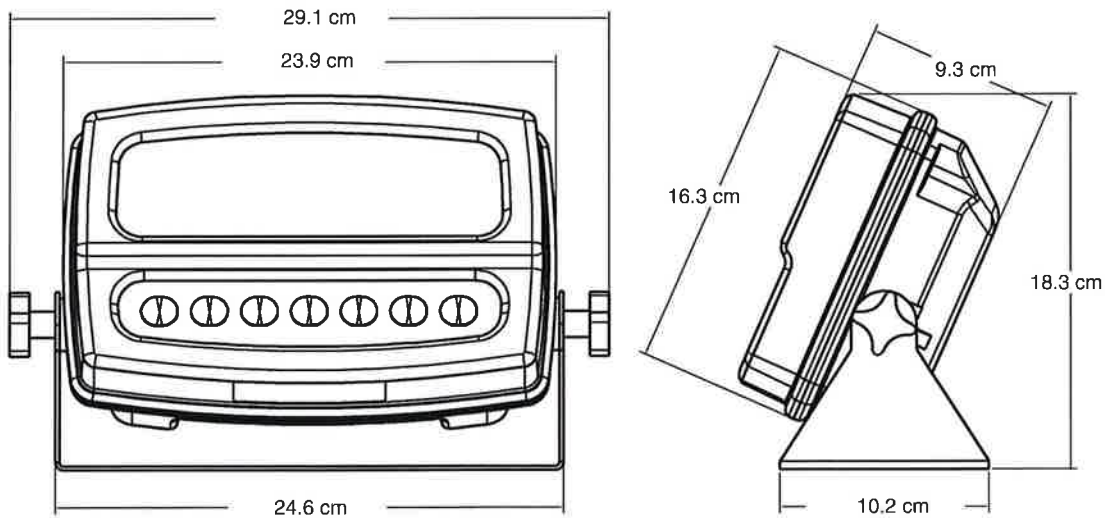

Nuweigh reserves the right to improve, enhance or modify features and specifications without prior notice. All registered trademarks are the property of their respective owners.

Distributed by:

NUWEIGH AUSTRALIA • 1300 885 746 • www.nuweigh.com.au

NWS PO Box 326 Wickham NSW 2293 • Established in 1976 • ABN 36 001 344 430

NWS
NUWEIGH